

High Efficiency RF Harvesting Antenna

Features

Harvesting SMD antenna

- Bundled SMD Antenna / Adaptation network
- Work in conjunction with high performance PMIC (AEM30xxx family) for RF energy harvesting (RFEH).

Ultra low power start-up

- PMIC cold starts from 275 mV input voltage and 3 μ W input power (typical)
- RF input power from -19 dBm up to 10 dBm (typical)

Compatible with wide transmitter power range

- Linear polarization for higher energy transfer efficiency from emitter to harvester
- Omni-directional pattern for better user experience
- +2 dBi max gain for better performances

Ultra compact design

- SMD antenna design: 10mm x 2.3mm x 2.3mm ceramic device built on glass epoxy substrate
- Compact RX Antenna PCB design (e.g. 6mm x 60mm)

Reference design

- EP112 evaluation board (EP112 EVK) comes with complete part list, layout, clearance area, matching network, SMA connector and PCB instructions for evaluation at 900 MHz and 2.4 GHz
- Compatible with any AEM30xxx EVK

Compatible with multiple frequency bands

- 863 – 870 MHz / 902 – 928 MHz / 2.4 GHz / 5 GHz

SMD design

- Standard Component re-flow profile (260C peak)
- No complex 3D antenna with metallic inlay

Multiple PCB form factor

- Design optimization for custom size PCB

Description

EP112 is the Virtual Antenna™ component for RF energy harvesting solution. It works at any frequency within the 100 MHz to 6 GHz band, and can be implemented with any of the e-peas AEM30xxx PMIC's.

The Virtual Antenna™ component EP112 allows to collect RF energy and becomes an integrated solution with the energy harvesting Power Management Integrated Circuit (PMIC) to provide IoT devices an endless battery life.

The EP112 is designed for RF energy harvesting enabling your device to recharge. The compact component turns your PCB into an antenna that receives energy for your wireless device on multiple frequencies, including the 868 MHz and 915 MHz or the 2.4 GHz - 2.5 GHz frequency bands. One of the main advantages of this product is that it can be easily tuned to these frequencies through the proper adjustment of the matching network.

The benefits are: small footprint, PCB standard mounting technology, lower cost, easy tuning (validation by simulation), easy fit in any wireless platform, off-the-shelf standard products.

EP112 device performances can be evaluated with e-peas EP112 evaluation boards (900 MHz or 2.4 GHz). These evaluation boards can be connected with either AEM30940 EVK or AEM30330 EVK.

Applications

- Asset Tracking/Monitoring
- Smart home/building
- Retail ESL/Smart sensors
- Industrial applications

Device Information

Part Number	Package	Body size [mm]
EP112	SMD	10 x 2.3 x 2.3mm

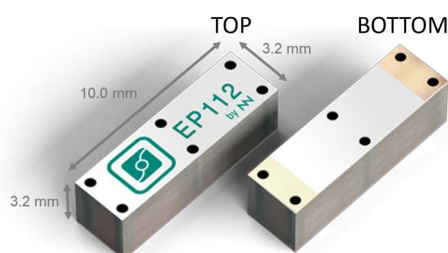

Table of Contents

1. Functional Block Diagram	3
2. Matching Network	4
3. PCB Layout Recommendations	5
3.1. Clearance Area	5
3.2. EP112 Location	5
3.3. EP112 Feeding Track	5
3.4. Matching Network	5
3.5. Materials	5
3.6. Multi-layer PCB	5
3.7. Transmission Line and RF Module	5
3.8. Ground Plane Layer	5
4. Evaluation Board for EP112	6
4.1. 863 - 929 MHz EVK	6
4.1.1. PCB Overview	6
4.1.2. RF Performance Data	7
4.1.3. Radiation Patterns	8
4.2. 2400 - 2500 MHz EVK	9
4.2.1. PCB Overview	9
4.2.2. RF Performance Data	10
4.2.3. Radiation Patterns	11
5. Packaging Information	12
5.1. Mechanical Drawing	12
5.2. Antenna Footprint	13
5.3. Assembly Process	14
5.4. Packing	16
6. Revision History	17

1. Functional Block Diagram

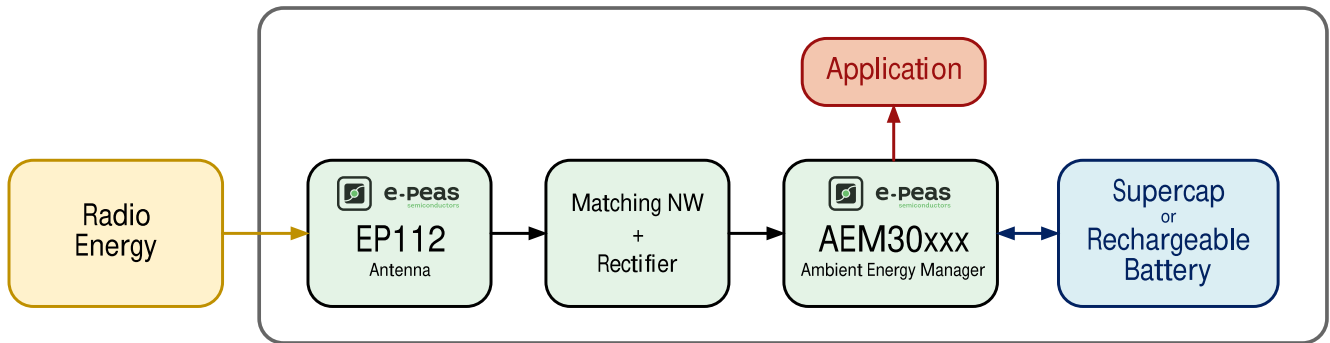

Figure 1: Functional block diagram

2. Matching Network

The Matching network lying close to the EP112 device is the key element to adapt the antenna harvester concept to the targeted frequency band. Flexibility of the design allows to layout one band, or another one or a multi-band network. The difference will come from the value of the discrete elements.

The product performances are measured in a specific Evaluation Board, which is an ideal case. In a real design, components near the antenna including LCD's, batteries, covers, connectors, etc. will affect the antenna's performance. Therefore, placing pads compatible with 0402 and 0603 SMD components for a matching network as close as possible to the feeding point is highly recommended. Placement should be done in the ground plane area and not

in the clearance area. This will provide flexibility to tune the EP112 antenna component once the design is finished while taking into consideration all elements of the system (batteries, displays, covers, etc.).

Please note that different devices with different ground planes and different components near the EP112 antenna component may require a different matching network. Please contact e-peas to support the design of a matching network that fits your design requirements.

To ensure optimal results, the use of high Q and tight tolerance components is highly recommended (Murata components).

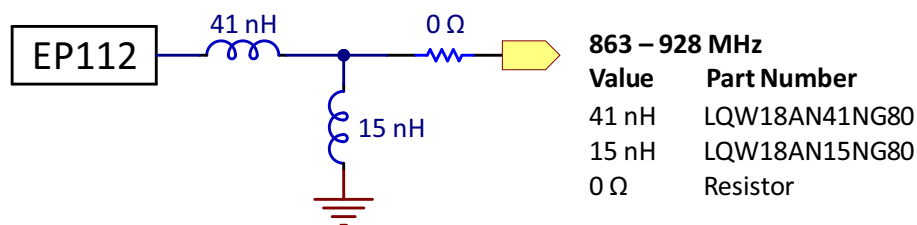

Figure 2: matching network example for 869-928 MHz frequency range (as on 900 MHz EVK)

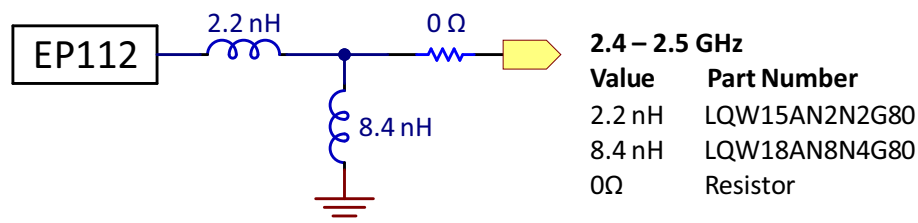

Figure 3: matching network example for 2.4-2.5 GHz frequency range (as on 2540 MHz EVK)

3. PCB Layout Recommendations

This section describes the main good practices to be considered when designing a PCB with the EP112 virtual antenna. Please contact e-peas for feasibility, early phase discussion and design validation.

3.1. Clearance Area

The EP112 component must be placed within a PCB zone that is free from electronic components and from any metallic element such as PCB traces, ground planes and power planes.

As a general rule, a 10 mm clearance to the ground layer in all directions around the antenna component is advisable. The clearance area must not contain any electronic components, traces and ground plane on all PCB layers including. This includes the underside of the antenna.

See Figure 5 and 8 for examples of clearance areas. Please note that the clearance area has been reduced on the 2.45 GHz antenna to show a PCB with smaller size.

3.2. EP112 Location

Keep the antenna around a corner of the PCB, as far as possible from other components, such as LCDs, batteries, connectors, especially those components and covers with metallic characteristics.

For best performances with a non-rectangular PCB, the antenna should be located on the outer corner that is across the longest side of the PCB. For a rectangular PCB any corner can be used.

3.3. EP112 Feeding Track

For all frequencies the recommended feeding track width is 1 mm.

For sub-GHz signal the feeding path a L-shaped track is recommended. For signals above 1 GHz a straight track is recommended with the antenna at the very corner of the PCB. See Figure 4 for illustrations of PCB routing.

3.4. Matching Network

Preferred component size is 0402/0603. Maximum performances are obtained when using high-Q and tight tolerance SMD components. Place pads as close as possible to the antenna feeding point and within the ground plane area. Modifying the values of the components in the matching network allows to refine the matching if needed.

3.5. Materials

Use low loss materials for the housings and enclosures.

3.6. Multi-layer PCB

Every track, plane or polygon connected to ground must be connected by vias.

3.7. Transmission Line and RF Module

Design your transmission line connecting the Matching Network to your RF module so that its characteristic impedance is 50 Ohms. Locate your RF module as close as possible to the matching network and rectifier to reduce the losses.

For the track between the matching network and the EP112 component, which is the track that runs on the clearance area, a 1 mm track width is recommended.

To avoid impedance discontinuities between the controlled impedance tracks we recommend to use 1 mm track width as this is the recommended width within the clearance area.

3.8. Ground Plane Layer

A continuous conducting ground plane must be present in at least one layer of the PCB. Maximizing the radiation performances is done by maximizing the surface of the PCB ground area.

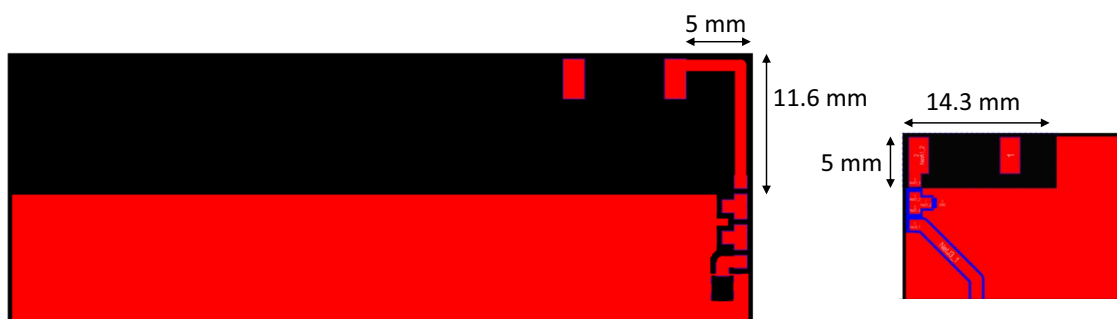

Figure 4: PCB tracks routing examples (left: 900MHz; right: 2.45GHz)

4. Evaluation Board for EP112

4.1. 863 - 929 MHz EVK

4.1.1. PCB Overview

The Evaluation Board (EVK) of the EP112 integrates an UFL cable to connect the EP112 antenna component with the SMA connector for easy performance testing.

- Material: the evaluation board is built on FR4 substrate.
- Thickness is 1 mm.
- E: distance between the EP112 antenna component and the ground plane.
- Clearance area: 61 mm x 11.6 mm (C x D).

The red dotted area is the recommended clearance area where no component should be laid-out.

This product is protected by several US patents.

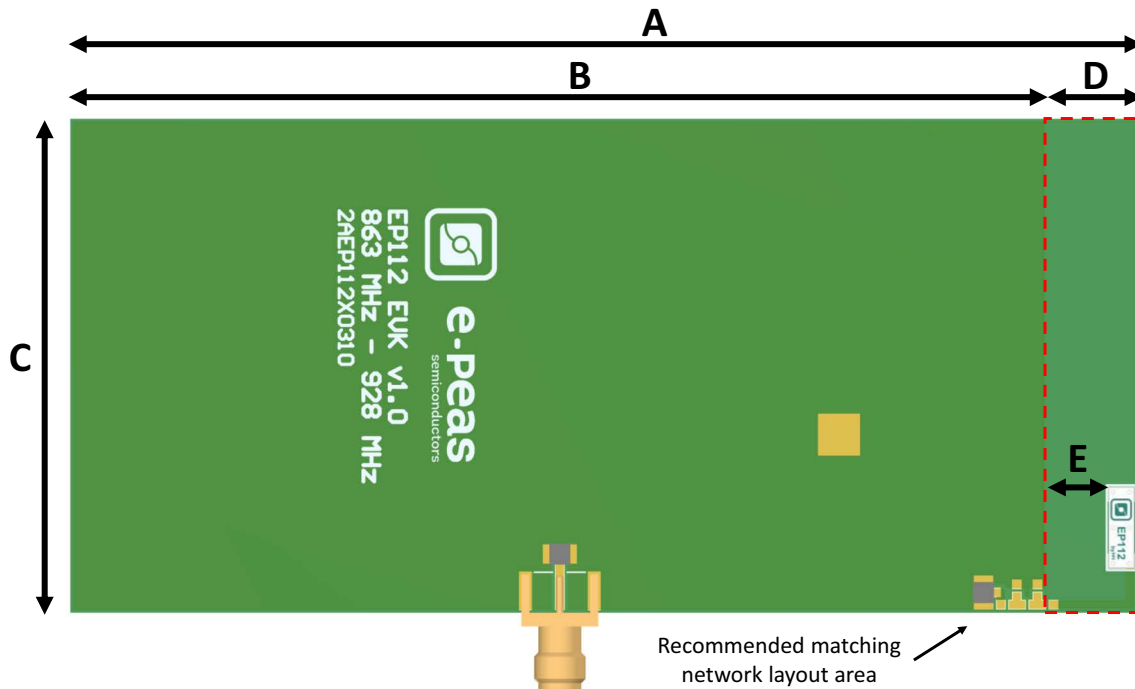

Figure 5: EP112 863-928 MHz EVK dimensions (drawing)

Measure	Value [mm]
A	132.0
B	120.0
C	61.0
D	11.6
E	7.9

Table 1: EP112 863-928 MHz EVK dimensions (values)

See Figure 2 for the 863-928 MHz EVK matching network schematic.

4.1.2. RF Performance Data

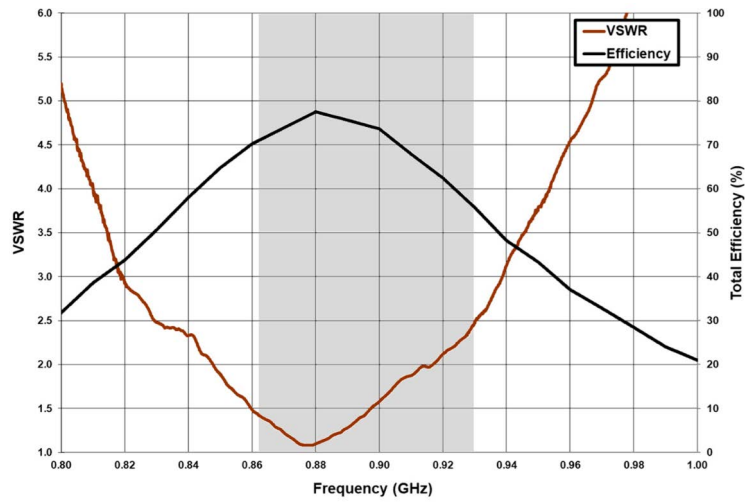
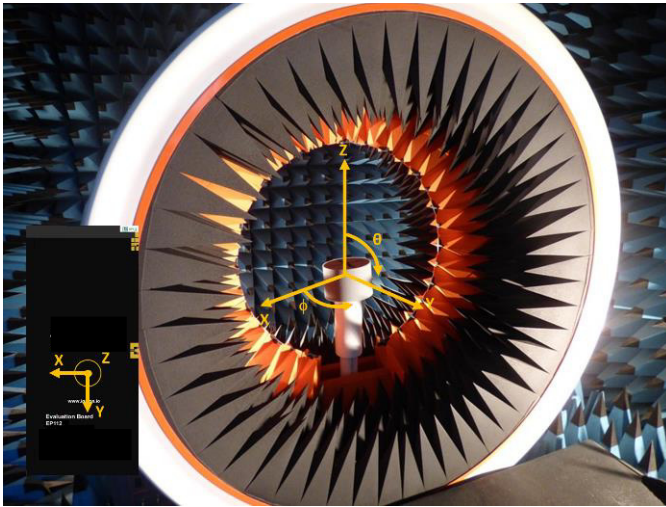

Figure 6: 900 MHz efficiency figures

	863 - 928 MHz
Peak gain	2.4 dBi
Average gain across the band	2.0 dBi
Gain range across the band	1.7 to 2.4 dBi
Peak efficiency	77.5%
Average efficiency across the band	>70%
Efficiency range across the band	57.9 to 77.5%

Table 2: EP112 performances for 863-929 MHz EVK

4.1.3. Radiation Patterns



Measurement system setup
Evaluation board in plane XY

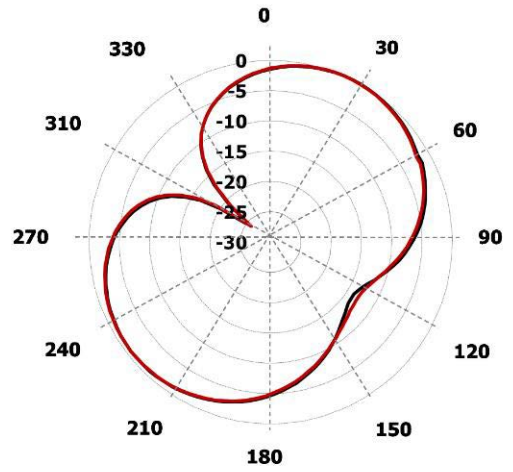

$\theta = 90^\circ$ plane XY at 868 MHz & 915 MHz

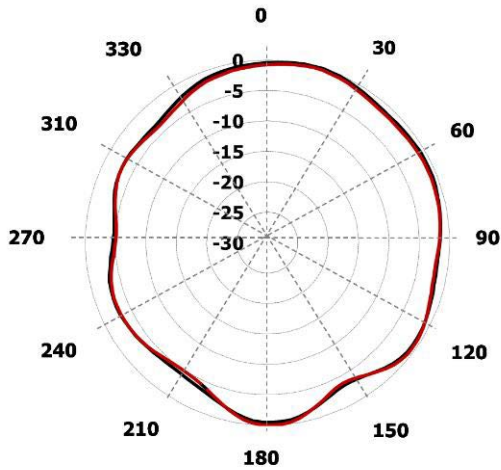

$\phi = 0^\circ$ Plane XZ at 868 MHz & 915 MHz

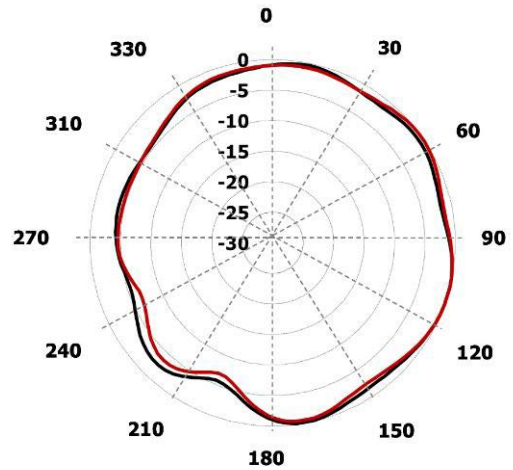

$\phi = 90^\circ$ Plane YZ at 868 MHz & 915 MHz

Figure 7: EP112 863 - 928 MHz radiation pattern

4.2. 2400 - 2500 MHz EVK

4.2.1. PCB Overview

The Evaluation Board (EVK) of the EP112 integrates an UFL cable to connect the EP112 antenna component with the SMA connector for easy performance testing.

- Material: the evaluation board is built on FR4 substrate.
- Thickness is 1 mm.
- E: distance between the EP112 antenna component and the ground plane.
- Clearance area: 14 mm x 5 mm (B x D).

The red dotted area is the recommended clearance area where no component should be laid-out.

This product is protected by several US patents.

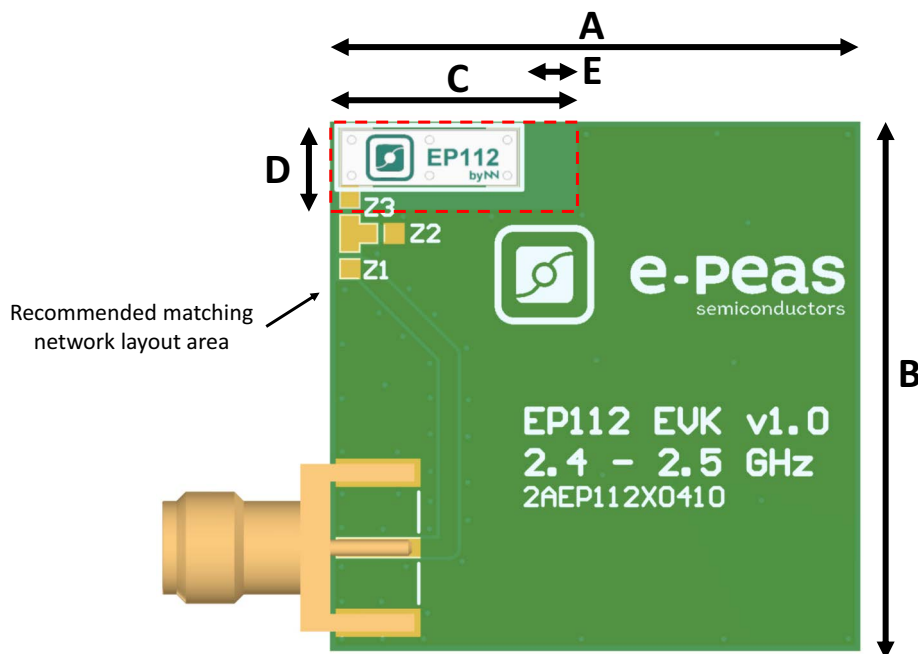

Figure 8: EP112 2.4-2.5 GHz EVK dimensions (drawing)

Measure	Value [mm]
A	30.0
B	30.0
C	14.0
D	5.0
E	3.4

Table 3: EP112 2.4-2.5 GHz EVK dimensions (values)

See Figure 3 for the 2.4-2.5 GHz EVK matching network schematic.

4.2.2. RF Performance Data

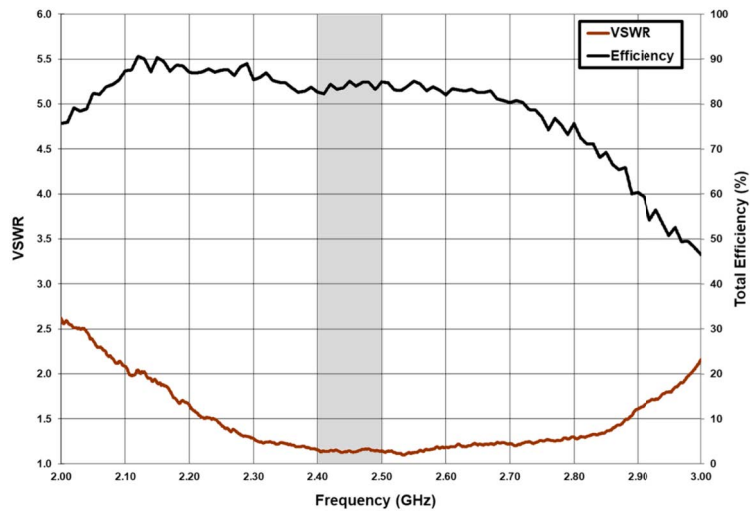
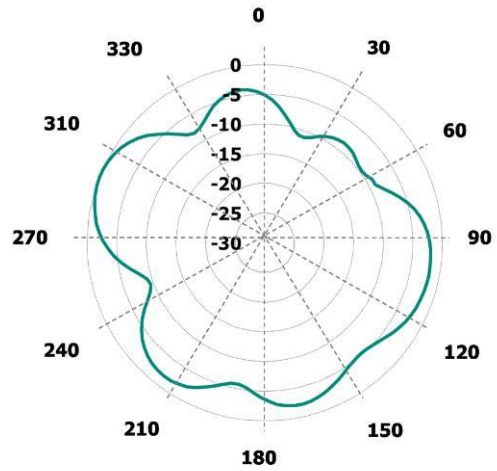
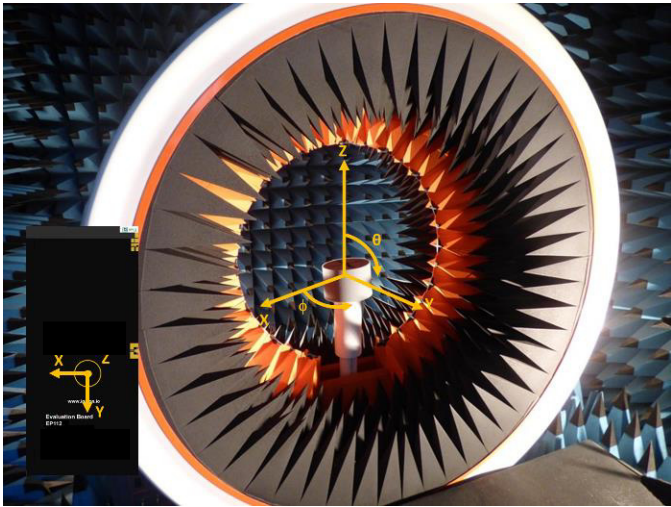

Figure 9: 2400 MHz efficiency figures

	2.4 - 2.5 GHz
Peak gain	2.0 dBi
Average gain across the band	2.0 dBi
Gain range across the band	1.9 to 2.1 dBi
Peak efficiency	85.1%
Average efficiency across the band	83.9%
Efficiency range across the band	82.3 to 85.1%

Table 4: EP112 performances for 2.4-2.5 GHz EVK

4.2.3. Radiation Patterns



Measurement system setup
Evaluation board in plane XY

$\theta = 90^\circ$ plane XY at 2450 MHz

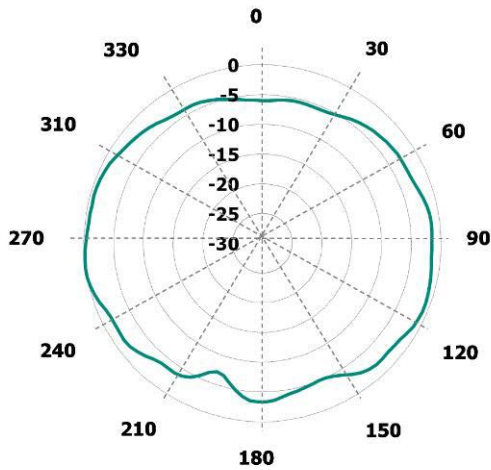

$\phi = 0^\circ$ Plane XZ at 2450 MHz

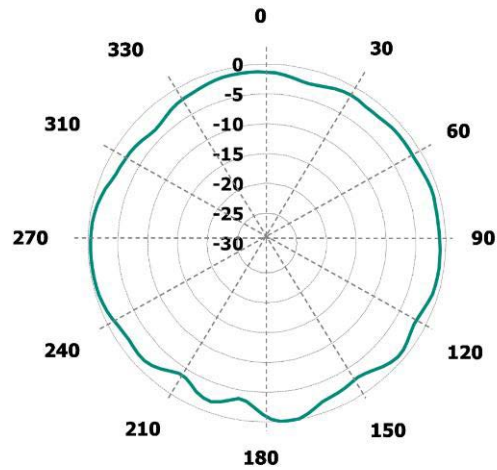

$\phi = 90^\circ$ Plane YZ at 2450 MHz

Figure 10: EP112 2400 - 2500 MHz radiation pattern

5. Packaging Information

5.1. Mechanical Drawing

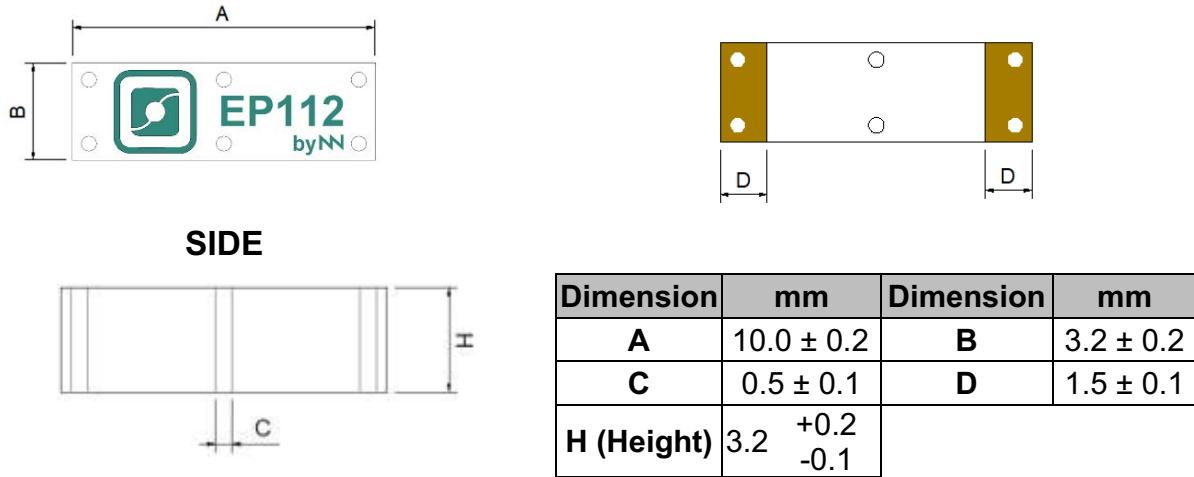

Figure 11: mechanical drawing

Both pads of EP112 are fully symmetrical to mount on the PCB. See Figure 11.

The EP112 is compliant with the Restriction of Hazardous Substances Directive (RoHS). The RoHS certificate can be provided upon request.

5.2. Antenna Footprint

Assuming that the EP112 antenna component is placed in the clearance area of the PCB, see below for the recommended footprint dimensions.

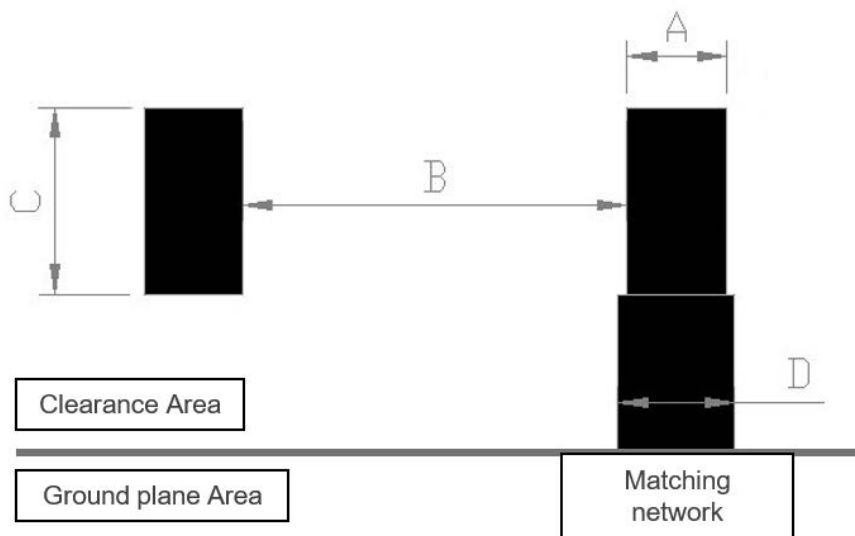

Measure	mm
A	1.7
B	6.8
C	3.2
D	2.0

Tolerance: ± 0.1 mm

Figure 12: Footprint dimension for a single instance

5.3. Assembly Process

Mounting Pad (2): solder the EP112 antenna booster mounting pad to the soldering pad on the PCB. This pad must NOT be grounded.

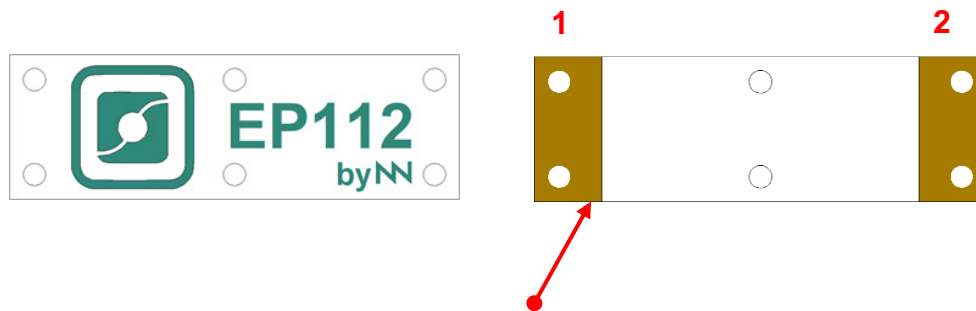

Feed Pad (1): The 2 pads are fully symmetrical. Once the feeding pad is selected (1), the other pad (2) will become a mounting pad. Align the feeding pad with the feeding line on the PCB.

Figure 13: mounting pads of EP112

Due to the symmetry in the product configuration, the feeding pad can be either of the 2 pads.

As a surface mount device (SMD), the EP112 antenna component is compatible with industry standard soldering processes. The basic assembly procedure for the EP112 antenna component is as follows:

- Apply a solder paste on the pads of the PCB. Place the EP112 device on the board.

- Perform a re-flow process according to the temperature profile detailed in Table 1, and 10.
- After soldering the EP112 device to the circuit board, perform a cleaning process to remove any residual flux. We recommend conducting a visual inspection after the cleaning process to verify that all reflux has been removed.

The drawing below shows the soldering details obtained after a correct assembly process:

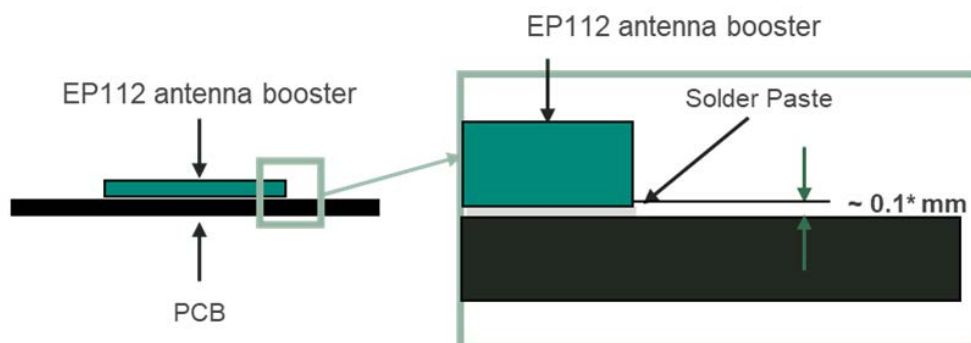

Figure 14: soldering details

NOTE: Solder paste thickness after the assembly process will depend on the thickness of the soldering stencil mask. A stencil thickness equal or larger than 127 microns (5 mils) is required.

The EP112 device can be assembled following the Pb-free assembly process. According to the Standard IPC/JEDEC J-STD-020C, the suggested temperature profile is as shown on Table 5:

Phase	Profile features	Pb-Free assembly (SnAgCu)
Ramp-up	Average ramp-up rate (T _{smax} to T _p)	3°C / second (max.)
Pre-heat	Temperature min. (T _{smin})	150 °C
	Temperature max. (T _{smax})	200 °C
	Time (t _{smin} to t _{smax})	60 - 180 seconds
Re-flow	Temperature (T _L)	217 °C
	Total time above T _L (t _L)	60 - 150 seconds
Peak	Temperature (T _p)	260 °C
	Time (t _p)	20 - 40 seconds
Ramp-down	Rate	6 °C / seconds max.
Time from 25 °C to peak temperature		8 minutes max.

Table 5: recommended soldering temperatures

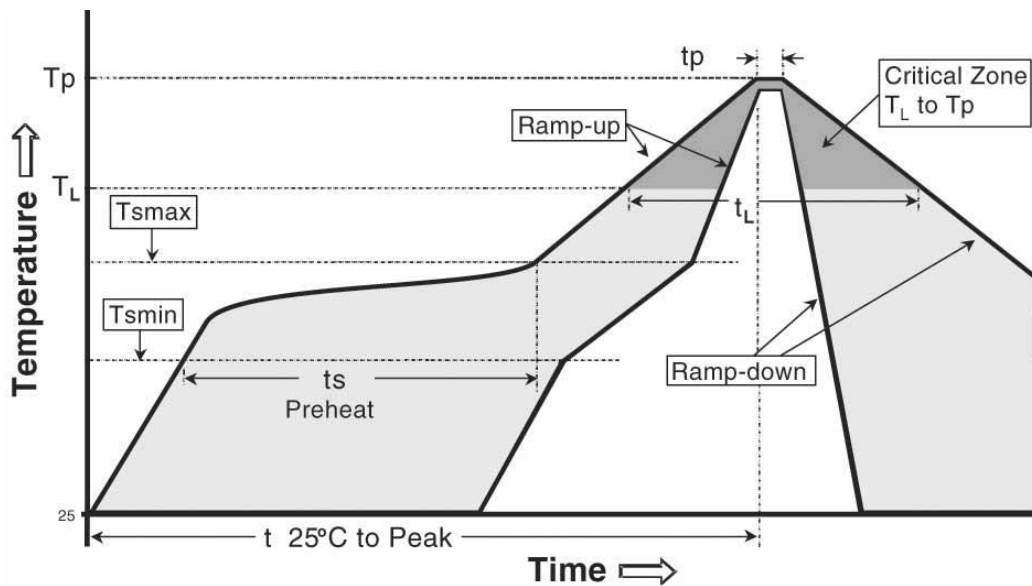
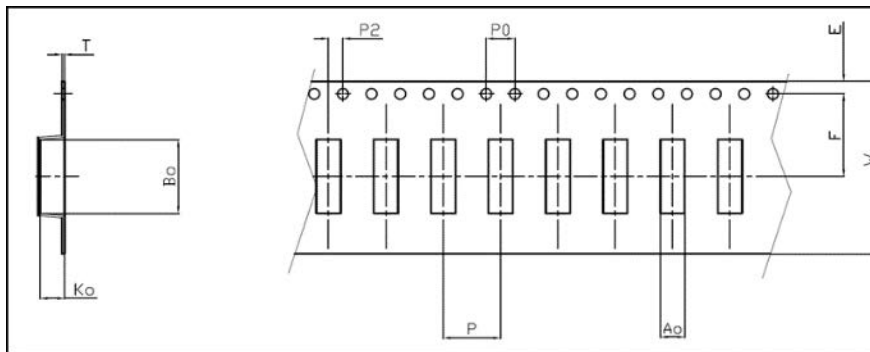

Figure 15: temperature profile for soldering

5.4. Packing



Measure	mm
Ao	3.4 ± 0.1
Bo	10.3 ± 0.1
Ko	3.4 ± 0.1
W	24.0 ± 0.3
P	8.0 ± 0.1
P0	4.0 ± 0.1
P2	2.0 ± 0.1
E	1.75 ± 0.1
F	11.5 ± 0.1
T	0.4 ± 0.05

Figure 16: tape dimensions and tolerances

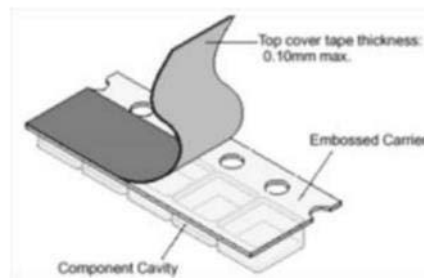
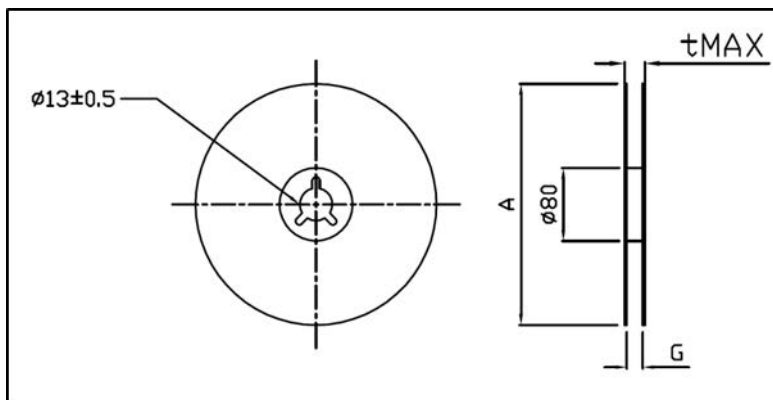

Figure 17: image of the tape



Measure	mm
A	330 ± 1.0
G	25.5 ± 0.2
tMAX	29.5 ± 0.2

Reel Capacity: 2000 pcs

Figure 18: reel details

6. Revision History

Revision	Date	Description
1.0	March, 2022	Creation of the document

Table 6: Revision history