

AEM10900 – WLCSP 16

Quick Start Guide EVK

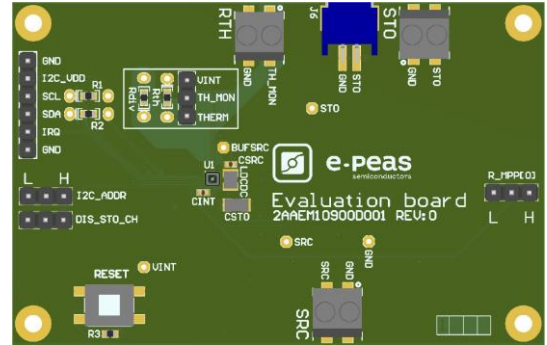

FEATURES

Connectors

- 1 screw connector for the photovoltaic cell.
- 1 screw connector + 1 JST connector for the storage element.
- 1 screw connector for thermal monitoring.

Configuration

- 1 R_MPP[0] header to define the MPP ratio linked to the harvester technology.
- 1 TH_MON header to enable/disable the thermal monitoring.
- 6-pin header for the I²C communication.
- 2 headers for the I2C_ADDR and DIS_STO_CH features.

Reset

- 1 reset button (press for 5 seconds minimum to reset the AEM).

Size

- 79mm x 49mm.
- 4 x M2.5 mounting holes.

SUPPORT PCB

BOM around the AEM10900

	Designator	Description	Quantity	Manufacturer	Part Number
Mandatory	U1	AEM10900	1	e-peas	order at sales@e-peas.com
	Battery	Battery with 2.8 V min. voltage	1	To be defined by user	
	LDCDC	Power inductor 6.8 µH 1.15A 1008	1	TDK	VLS252012HBX-6R8M-1
	CSRC	Ceramic capacitor 22 µF 6.3 V 20% X5R 0402	1	Murata	GRM158R60J226ME01
	CINT	Ceramic capacitor 22 µF 6.3 V 20% X5R 0402	1	Murata	GRM158R60J226ME01
Optional	CSTO	Ceramic capacitor 22 µF 6.3 V 20% X5R 0402	1	Murata	GRM158R60J226ME01
	RZMPP	Resistor for ZMPP functionality	1	To be defined by user	
	R1, R2	Pull-up 1kΩ Resistors for I ² C interface	2	Yageo	AC0603FR-071KL
	Rth	10kΩ NTC thermistor for temperature monitoring	1	Murata	NCP15XH103J03RC
	Rdiv	Resistor 22kΩ 1%	1	Yageo	PNRC0402FR-0722KL

Footprint & Symbol: information available on the datasheet.





STEP 1: AEM10900 WLCSP 16 configuration



- MPP timing :**

Configuration	Availability Through Pins		MPP Timing	
	I ² C Interface ¹	Configuration pins ²	Sampling duration T _{VOC} [ms]	Sampling period T _{MPPT} [ms]
LLL	yes	no	2	64
LLH	yes	no	256	16384
LHL	yes	no	64	4096
LHH	yes	no	8	1024
HLL	yes	no	4	256
HLH	yes	no	2	128
HHL	yes	no	4	512
HHH	yes	yes	2	256

1. For I²C configuration, T_MPP[2:0] value is set thanks to the MPPTCFG[6:4] register (see datasheet).
 2. T_MPP[2:0] configuration only available by I²C interface (default configuration is HHH).

- MPP ratio: R_MPP[0]** (seen as HIGH if left floating)

Configuration	Availability Through Pins		MPPT ratio
	I ² C Interface ¹	Configuration pins ²	
R_MPP[3:0]	I ² C Interface ¹	Configuration pins ²	V _{MPP} / V _{OC}
LLLL	yes	no	Reserved
LLLH	yes	no	90%
LLHL	yes	no	65%
LLHH	yes	no	60%
LHLH	yes	no	85%
LHLH	yes	no	75%
LHHL	yes	yes	70%
LHHH	yes	yes	80%
HLLL	yes	no	35%
HLLH	yes	no	50%

1. For I²C configuration, R_MPP[3:0] value is set thanks to the MPPTCFG[3:0] register (see datasheet).
 2. Only R_MPP[0] setting is available by GPIO configuration (R_MPP[3:1] = LHH in that case).

- Storage element threshold voltages:**

Configuration	Availability Through Pins		Storage Element Threshold Voltage	
	I ² C Interface	Configuration pins	V _{OVCH}	V _{OVDIS}
STO_CFG[2:0] ¹	I ² C Interface	Configuration pins	V _{OVCH}	V _{OVDIS}
LLL	yes	no	4.50 V	3.30 V
LLH	yes	no	4.00 V	2.80 V
LHL	yes	no	3.63 V	2.80 V
LHH	yes	no	3.90 V	2.80 V
HLL	yes	no	3.90 V	3.50 V
HLH	yes	no	3.90 V	3.01 V
HHL	yes	no	4.35 V	3.01 V
HHH	yes	yes	4.12 V	3.01 V

1. STO_CFG[2:0] configuration only available by I²C interface (default configuration is HHH).

- Thermal monitoring:**

Enable thermal monitoring by placing a jumper on the dedicated header to connect TH_MON to THERM.

Disable thermal monitoring by placing a jumper on the dedicated header to connect TH_MON to VINT.

- Configuration mode:**

- DIS_STO_CH : Connect to L to enable the charge of the storage element, connect to H to disable it (seen as LOW if left floating).
- I2C_ADDR: Connect to H for AEM I²C address = 0x41, connect to L for I²C address = 0x40 (seen as HIGH if left floating).

- I²C communication:**

All the AEM configurations, as well as various information are available through I²C communication. See the AEM00900 datasheet for more details.

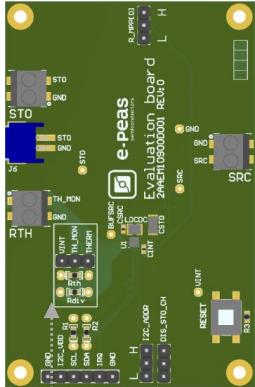



STEP 2: Connect a storage element with a voltage higher than 2.8 V

STEP 3: Connect a photovoltaic single cell

- Internal boost efficiency vs. input voltage (LDCDC = 6.8 μ H):

